



TECHNICAL DESIGN ASSIGNMENT FOR GLASSWARE

Section I. Customer

1. Company`s name _____

2. Details _____

Section II. Design objective

What would you like to order?

1. Development the general view of glassware _____

2. Glassware _____

3. Development the design documentation for molds _____

4. Moulds _____

Section III. General glassware data

1. Glass containers` name _____

2. Serial number _____

3. Your requirements _____

4. Rated capacity _____

5. Filling level or total capacity _____

6. Recommended weight, g _____

7. Finish size _____

8. Finish type

as per GOST 10117.2-2001 _____

as per any foreign standard _____

alterations _____

9. Cap / lid type (check as appropriate)

38x28	60x32	44x28	43x32	44x38	Other

10. Overall dimensions _____



11. Decoration type

- label silkscreen

12. Label type

- 12.1. solid discrete
12.2. paper sticker

13. Label field sizes on glassware _____

14. Label field location on glassware _____

15. Bottle orientator: yes no

15.1. Kind of the bottle orientator _____

15.2. Its location _____

15.3. Sizes _____

16. Engraving (logo, text, ...): yes no

16.1. Sizes _____

16.2. Location _____

16.3. Sketch engraving: available not available

17. Mandatory technological marking

17.1. Includes:

- trademark
- rated capacity
- filling level or total capacity
- year of production
- mould number
- manipulation marks

17.2. Location

- at the discretion of the manufacturing plant
 lower part
 combined type
 bottom

Section IV. Special additional requirements to glassware



Section V. Patent rights

- 1. General view patented: yes no
- 2. Glassware sketch availability available not available
- 3. Glassware sample availability available not available

Section VI. Packaging requirements

1. Package size

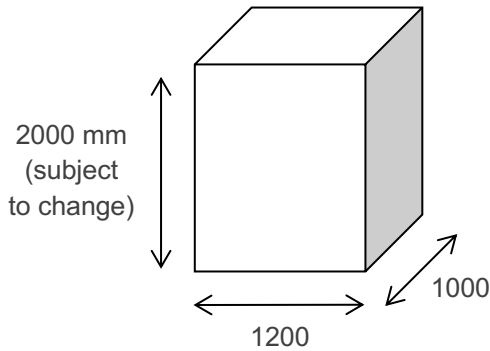

2. Pelletization variant

- box above box below flat sheet and tape;
 - bottom row top row
-

Section VII. Filling line

- 1. Type of bottled product for the glassware _____
- 2. Pressure (for soda) _____
- 3. Bottling type (for wine) (check as appropriate):
 hot cold no information available
- 4. Type of filling lines used the enterprise _____
- 5. Filling speed _____
- 6. Filling type (check as appropriate):
 by volume by level no information
- 7. Diameter of a filling shaft tube _____



Section VIII. Customer data

1. Are there any storage facilities for bottles in your company?

yes no

2. Have you ever ordered a glassware (moulds) based on this general view?

yes no

What enterprise it was from? _____

Have you satisfied with the quality of the glassware (moulds) received?

yes no

Do you want to change it?

yes no

What is it exactly? _____

3. Which batch of bottles would you like to order? _____

4. Expected date of glassware delivery _____

Section IX. Customer's additional conditions

Customer (signature, printed name) _____

Please send the completed document via email d.kuraev@avangard-steklo.com